

ICSV14
Cairns • Australia
9-12 July, 2007



NO WORRIES – HOW TO HANDLE ACOUSTICAL PLANNING PROBLEMS WITH NOISE CALCULATION SOFTWARE

Wolfgang Probst

ACCON GmbH and DataKustik GmbH
D-86926 Greifenberg, Germany
Wolfgang.probst@datakustik.de

Abstract

Prediction and assessment of noise is extremely important in the planning phase of new roads, railway tracks, industrial facilities or airports near cities and other built up areas. The calculation of noise levels allows a detailed analysis of the source influence and the spatial distribution presented as noise map is an excellent basis to optimize the layout of all planned constructions. Several tools have been developed to support the architects and planners in their task to rank different solutions, to implement effective noise mitigation measures and to find the optimal alternative with respect to noise. Some of these techniques are demonstrated.

1. INTRODUCTION

The basic element of a noise prediction for any facility is the calculation of the noise level produced by a point source in a given position relative to the receiver point. These calculations are carried out by using algorithms that are laid down in standards and guidelines. The rules how to calculate the noise caused by point sources and extended line- or area sources are laid down in national and international standards and implemented in software packages for noise prediction /1/.

But these basic procedures are only a starting point – the development of highly efficient computer hardware made it possible to integrate more and more modelling and assessment tools that link the noise calculation with other applications and help acousticians and environmental engineers to use the knowledge and power of related disciplines.

Common for all applications – traffic- and industrial noise prediction – is the possibility to import geometrical data of the terrain and in many cases from the buildings from GIS (Geographical Information Systems), from laser scans or from other sources.

With industrial noise special tools can be used to predict the emission data of technical devices like motors, pumps, piping and cooling towers from the known technical parameters like electric power, speeds, revolutions per time or cooling capacity. This allows the engineer to avoid doing research in technical literature again and again and to develop his own expert system for noise emissions /2/.

With traffic noise from roads and railways it is also quite important to use existing data from GIS and import them directly. The noise calculation program should be able to handle

complex and elevated roads – this means that the diffraction around the edges of an elevated road must be calculated to get correct results for residential areas with flyovers.

It depends on the problem to be solved where the noise levels have to be calculated. The basic procedure is to calculate at well defined receiver points. The spatial distribution of noise is presented calculating the noise on grids of receivers. But if the noise impact on residential areas shall be assessed it is advantageous to calculate at receiver points distributed on the building facades. These “façade levels” are the basis to determine noise scores based on the noise level and on the number of people affected. A new technique to inspect the complete environment and all the built up areas around a noise radiating device is to export a 3D-model to Google™Earth. This powerful technique allows to integrate the project visually in the complete city model.

CREATING THE TERRAIN MODEL

In 3D models the terrain is defined by lines and point with given absolute heights. These contour lines and height points are imported and the program should simulate a mesh defining the ground height in any position.

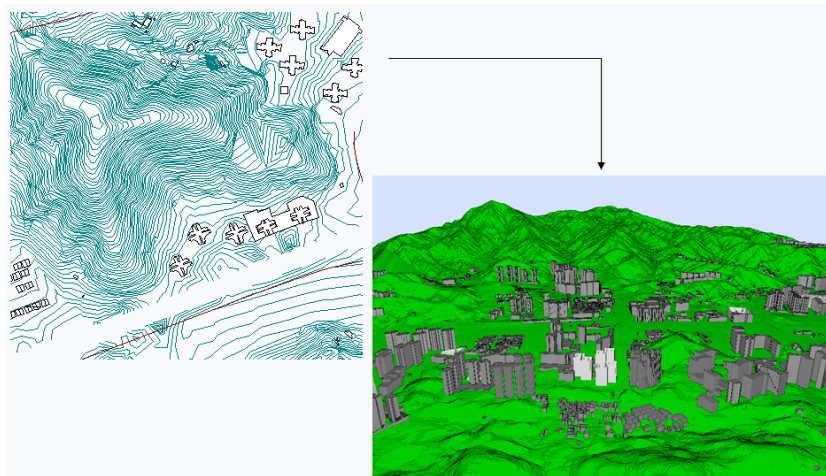

Figure 1. Based on the lines of height (contour lines), the ground surface is generated and can be displayed in 3D-views

Some models may be too large to handle them in one project file – even in these cases there is always a solution, e. g. by simplifying the geometry (reduce automatically the number of points and separate it automatically in different tiles of some km² each).

EMISSION OF INDUSTRIAL SOURCES FROM TECHNICAL PARAMETERS

The calculation of the noise produced by industrial facilities is one of the most important applications of noise prediction software. If a 3D-model of a production plant has been developed, it is easy to take into account environmental aspects in all further modifications or extensions in the planning phase. The 3D noise model makes it an easy job to decide how the noise impact in a neighbouring flat will change if a new cooling tower or any other device will be installed.

With the special additional option SET (Sound Emission and Transmission) for the noise prediction program CadnaA it is possible to determine the sound power spectra of technical devices from the technical parameters.

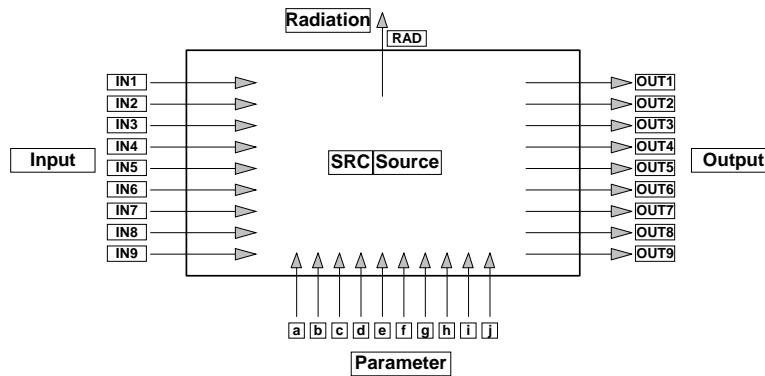

Figure 2 The software module SET

Figure 2 shows the principle of the software module SET. Based on this module about 150 technical sources have been implemented and the user is able to use this structure to create his own models of complex technical sources. The module has 9 ports to import and to export spectra, 10 ports to import parameter values and one port to connect it with a source in the 3D-model – this is the spectrum radiated from the source. Inputs and outputs can be connected to other modules. The source is a program that calculates the spectrum from the parameters.

This structure allows to simulate any complex system, where the sound power is generated, partly radiated and partly transmitted to other parts of the facility. An example is the cooling tower, where noise is generated by the fan, motor and gear driving it and by the falling water drops.



4-cell-cooling tower

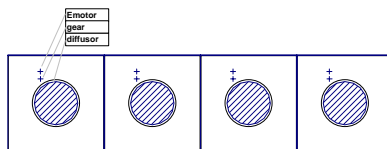

CadnaA-model top view

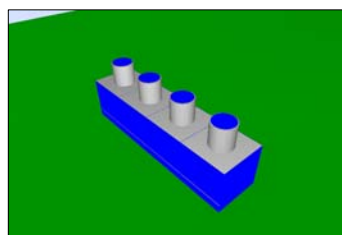

CadnaA-model 3D-view

Figure 3 Modelling a cooling tower with the different radiating parts

Another example is the hose filter that is used in exhaust gas cleaning systems (figure 4)

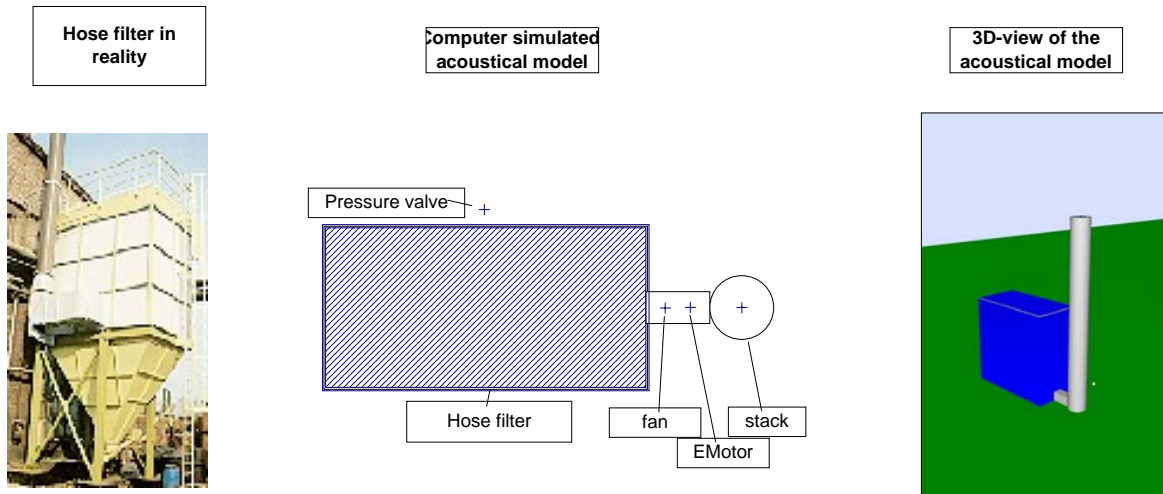

Figure 4 Detailed modelling of an exhaust gas cleaning with a hose filter

The discussed noise prediction software covers a tremendous large span from such detailed models of technical sources up to the simulation of complete factories – figure 5 shows a car production factory with more than 3500 point sources to simulate the noise producing devices in the plant.

TRAFFIC SOURCES

The main application is without doubt the calculation of noise caused by roads and railways. The noise calculation program allows to import the geometrical data direct from GIS or related systems. Complete cities like Vienna, Munich, Bratislava and Lisbon have been modelled that way and noise maps of some 1000 km² have been calculated.

The main advantage of such large models is that they can be used to include the aspect of noise and air pollution in many other political and technical decisions. While a noise expertise is generally an expensive and time consuming task, it is an easy step to cut out the relevant part from the complete city model, to modify it according to the planned situation and to recalculate the noise distribution.

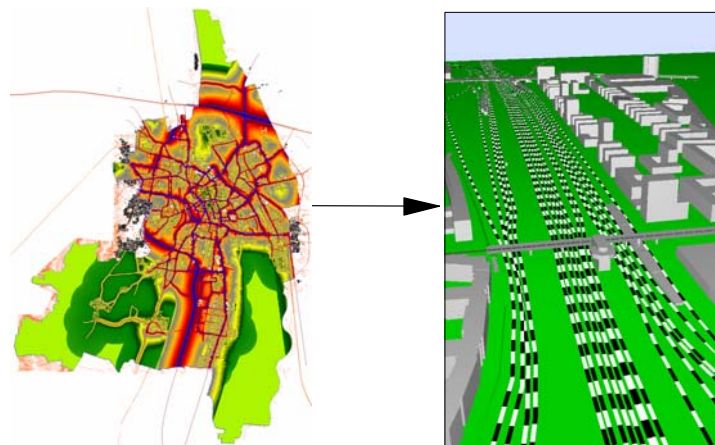

Figure 5 3D-Model of a city with noise map (left) and detail at railway station (right)

In many cases it is of interest to take into account the scenario in the vicinity of the part of a city where the noise is investigated. The new tool “Export to GoogleTMEarth” allows it to export the complete model from the noise calculation software into GoogleTMEarth. Figure 6 shows the screen presentation after having imported the model shown in figure 5 at the right side.

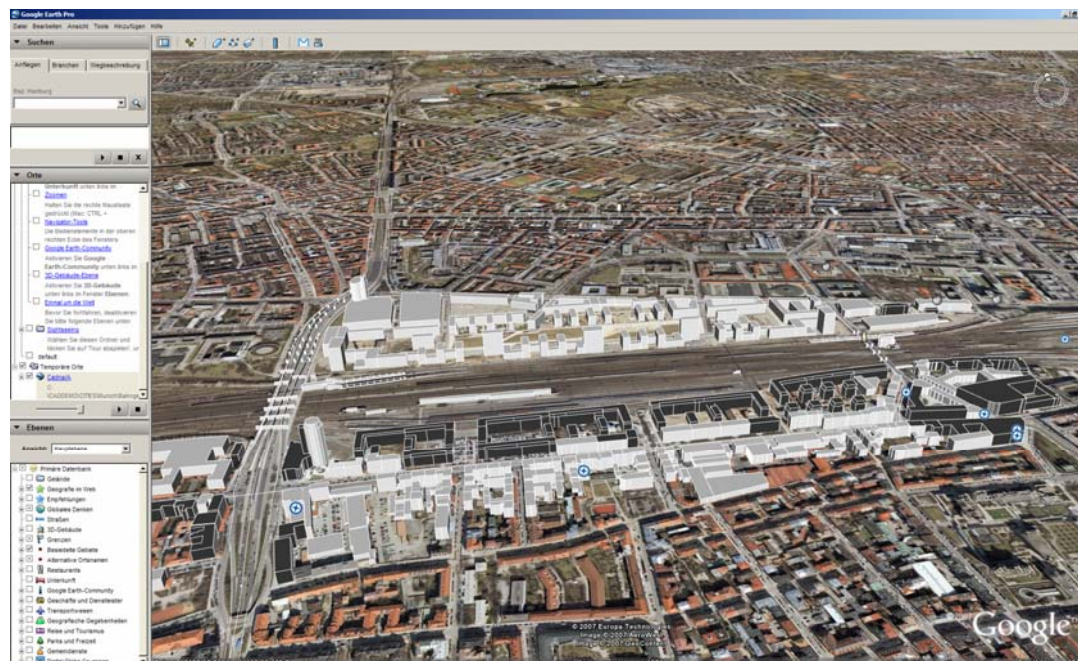

Figure 6 The built up areas around the railway track – exported from the noise prediction software CadnaA to GoogleTMEarth

These techniques and many others help the acoustician to organize his work in the environment of a city administration.

CONCLUSION

Prediction of noise and air pollution is increasingly based on complete 3D-models of the environment. Beside the implemented calculation standards the the noise specialist or consultant is supported by many software tools that help him to model the environment, to find out the correct sound emission values related to the technical parameters and to inspect his model in an integrated 3D-viewer or in GoogleTMEarth.

REFERENCES

- /1/ “SET – Sound Emission and Transmission”, brochure published by DataKustik GmbH, info@datakustik.de
- /2/ “CadnaA – Software for Environmental Noise”, brochure published by DataKustik GmbH, info@datakustik.de